

# MEDIUM/HIGH TEMPERATURE HOSE FOR TEMPERATURES UP TO +570°F

## Master-Clip ISO-CAR

### Material

Hose wall double layer: inner layer heat resistant impregnated glass fabric, outer layer special coated high-temperature fabric  
External helix: galvanized steel

### Applications

- Machine manufacturing
- Automotive manufacturing
- Aircraft manufacturing
- Suction plants
- Diesel engine test-benches with higher extraction Performance
- Defense systems
- General engineering
- Hot air
- Smoke extractors
- Low pressure applications

### Properties

- Flame-resistant
- Very good temperature resistance
- Vibration-proof
- High resistance to mechanical loads
- Highly flexible
- Compressibility 1:4
- Small bend radius
- Good vacuum resistance
- Abrasion-resistant
- Primarily suitable as exhaust hose
- External steel helix protects against abrasion
- Special clamping method guarantees high tensile strength between hose material and external helix
- To maximize life of duct and exhaust system effectiveness, it is recommended to utilize a negative pressure exhaust system and introduce ambient air at the inlet.



### Construction

1. External helix
2. Outer wall: special-coated high temperature fabric
3. Inner wall: heat resistant impregnated glass fabric

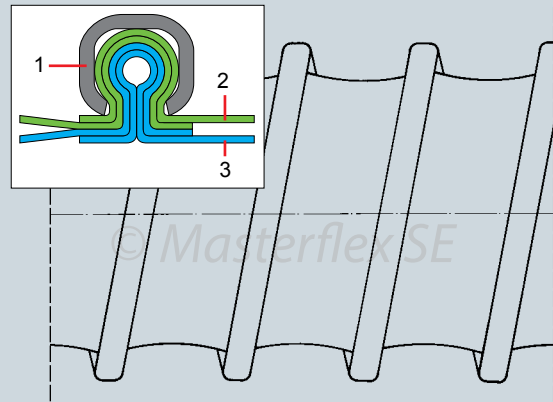

### Temperature Range

- -75°F up to +570°F\*
- Intermittent to +660°F

\*Hoses used for vehicle exhaust extraction should be used within a properly designed, negative pressure fan system to avoid damaging the hose. Please consult your local vehicle exhaust representative for more details.

# Master-Clip ISO-CAR

Dia (in.)	Positive (in. w.c.)	Negative (in. w.c.)	*Bending radius (in.)	Weight (lbs./ft.)	Product Code
2.50	273	105	1.56	0.5368	226-063-120
3.00	249	85	1.80	0.6710	226-075-120
3.50	225	66	2.16	0.8052	226-090-120
4.00	205	53	2.40	0.8723	226-100-120
4.50	193	44	2.64	0.8723	226-115-120
5.00	133	33	3.00	0.9394	226-125-120
5.50	100	28	3.36	1.0736	226-140-120
6.00	88	24	3.60	1.2078	226-150-120
6.40	84	22	3.84	1.2078	226-160-120
7.00	74	18	4.20	1.4091	226-175-120
8.00	59	13	5.60	1.6104	226-200-120
9.00	46	11	6.32	1.3420	226-226-120
10.00	40	9	7.00	1.4762	226-250-120
11.00	32	7	7.72	1.5433	226-275-120
12.00	28	6	8.40	1.6104	226-300-120
13.00	24	5	9.12	1.6775	226-325-120
14.00	23	5	9.80	1.9459	226-350-120
15.00	20	4	12.00	2.1472	226-375-120
16.00	19	3	12.80	2.2814	226-400-120
18.00	18	3	14.40	2.6840	226-450-120
20.00	17	2	16.00	3.0195	226-500-120
22.00	17	2	17.60	3.4221	226-550-120
24.00	16	2	19.20	3.7576	226-600-120
28.00	12	1	22.40	4.4286	226-700-120
32.00	9	1	25.60	5.0996	226-800-120
36.00	6	1	28.80	5.7706	226-900-120

\*Referring to the inner side of the elbow of hose.  
The above mentioned data refers to an average and ambient temperature of 68° F. Subject to technical changes and color variations. Please refer to technical data sheet when selecting hose.

## Standard Production

- Diameter: 2.5" to 36"
- Color: inside silver-gray, outside green-gray
- Standard lengths: 25'

## Available on Request

- Special lengths
- Custom design with other pitches and helix sizes
- External helix also in stainless steel
- Special diameters metric

## Installation and connection possibilities



Clip-Grip hose clamp, screwable



Hose connector



Hose reducer, symmetrical